

DEWALT

www.DEWALT.eu

D27111

D27112

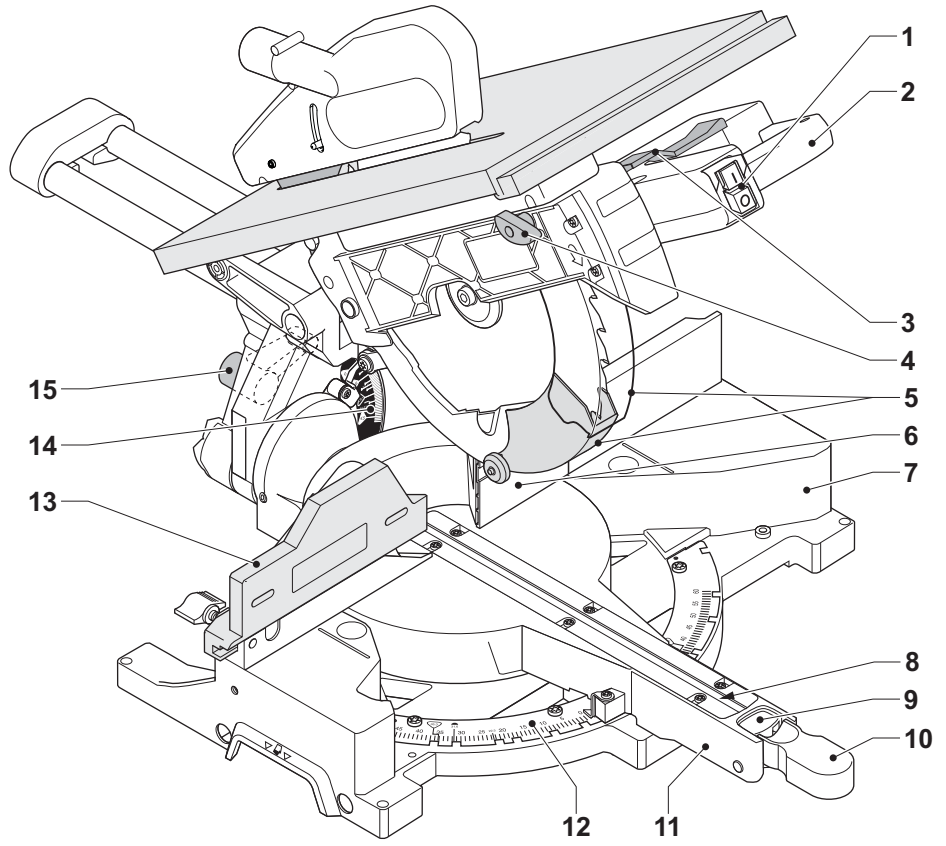
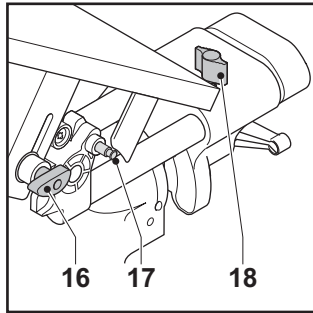

A1

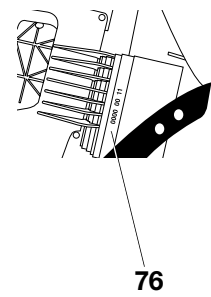
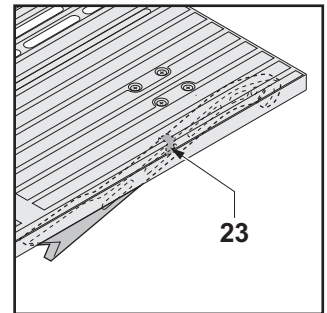
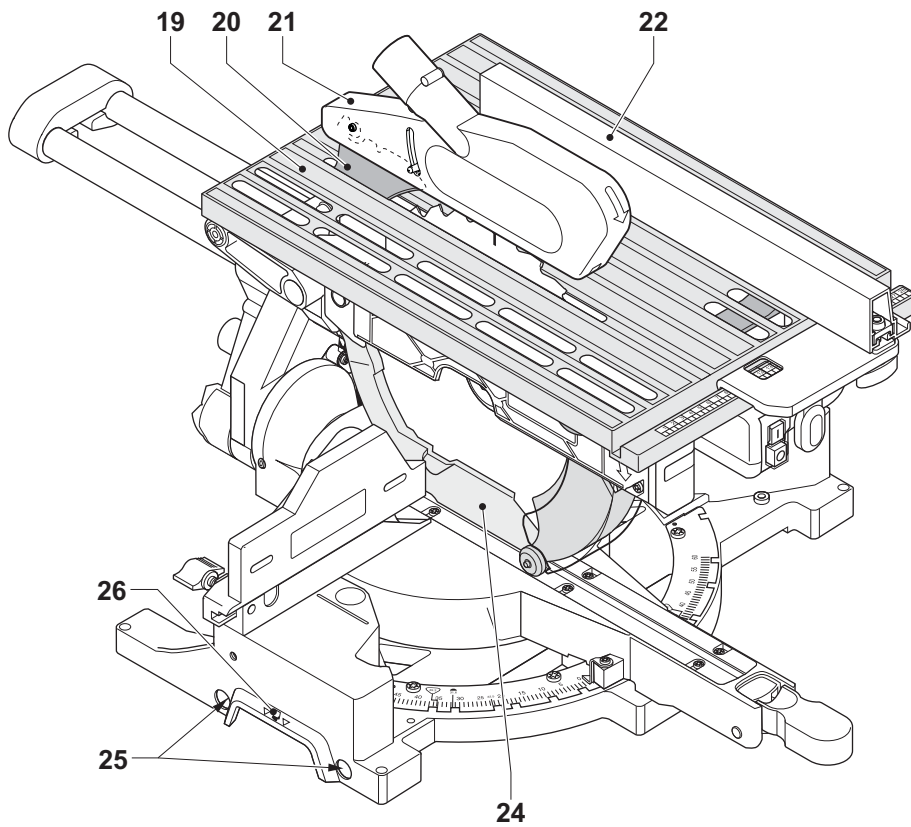

A2

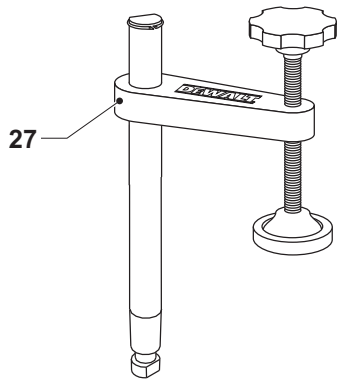

A3

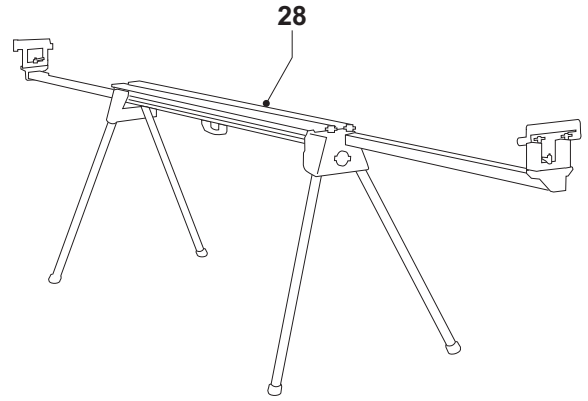

A4

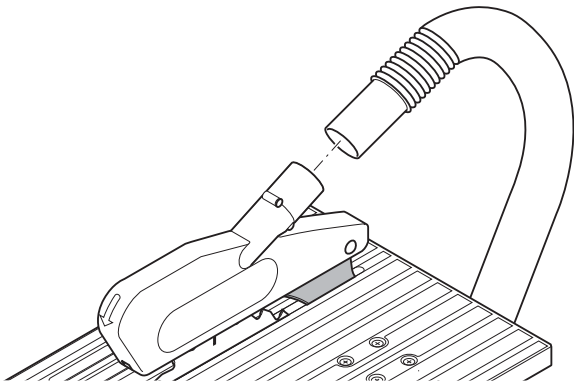

A5

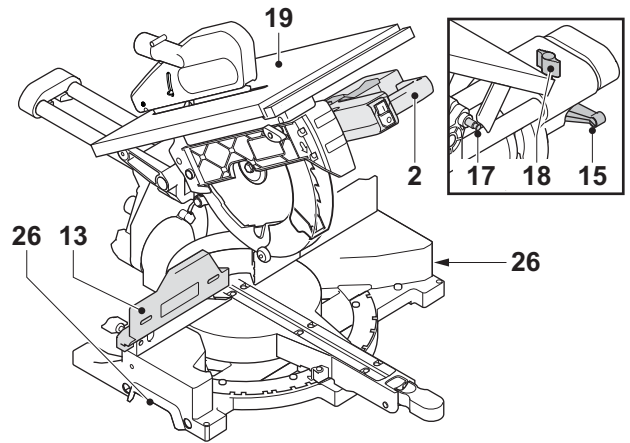

B

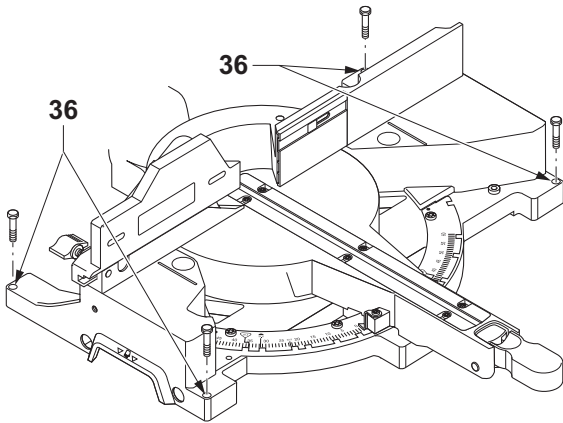

C

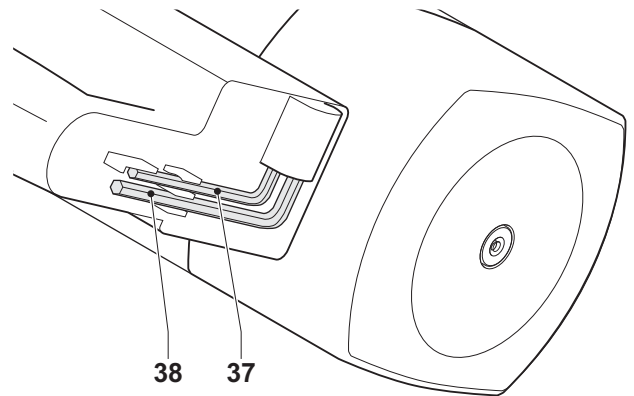

D

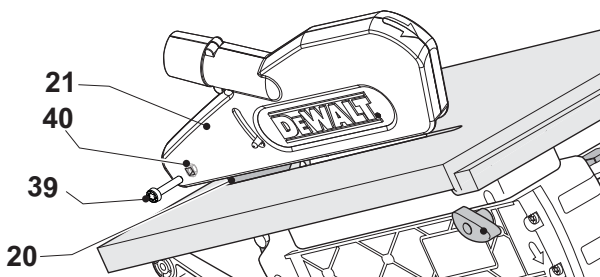

E

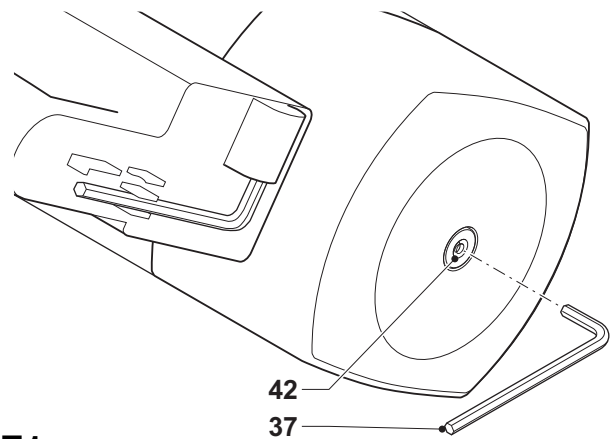

F1

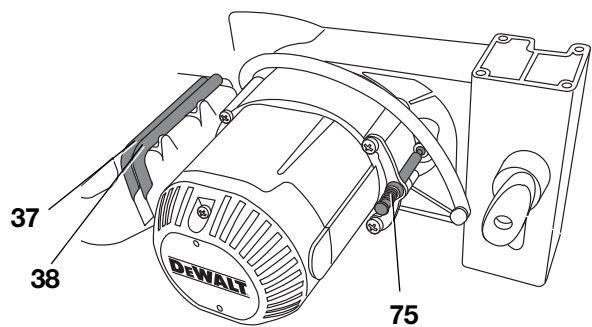

F2

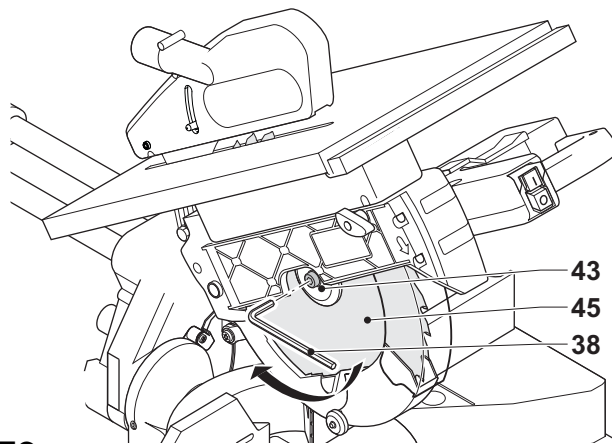

F3

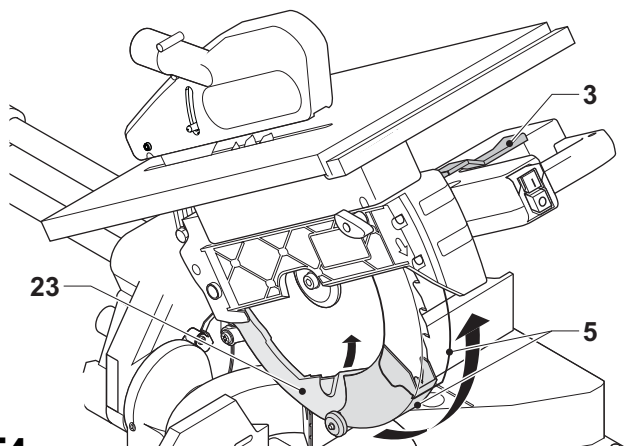

F4

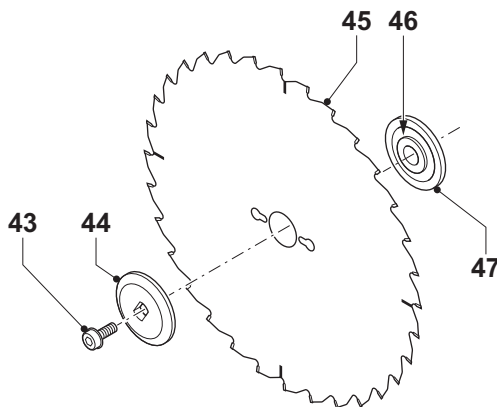

F5

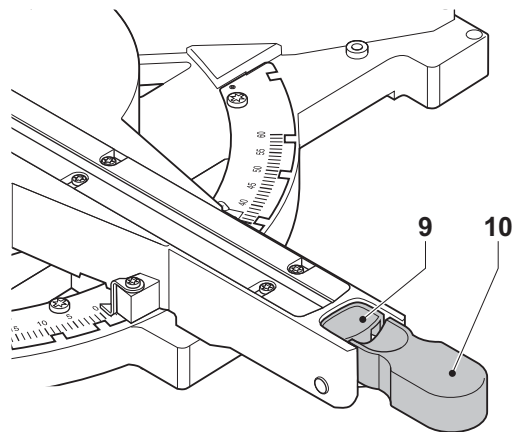

G1

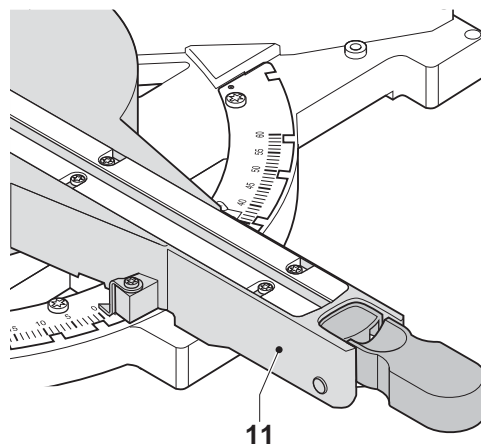

G2

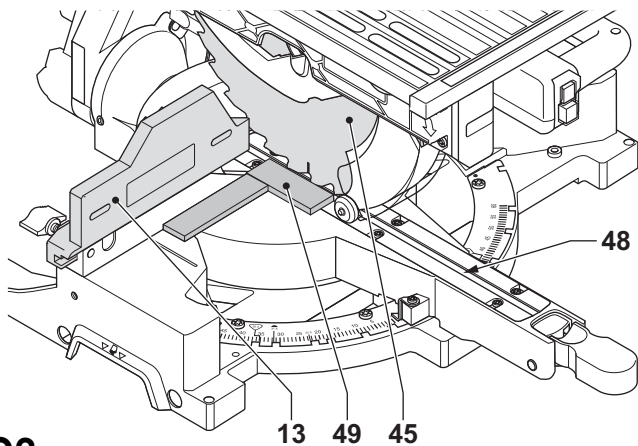

G3

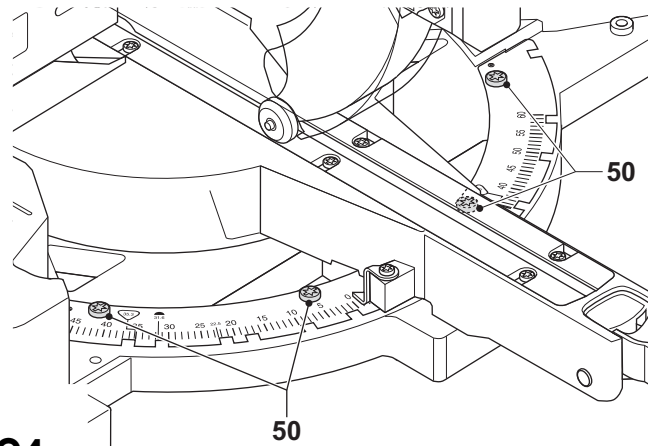

G4

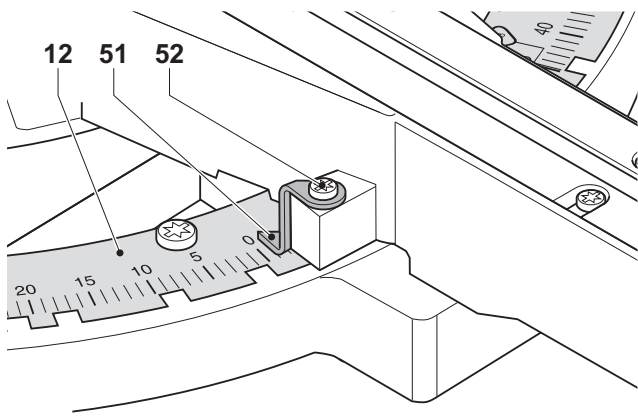

H

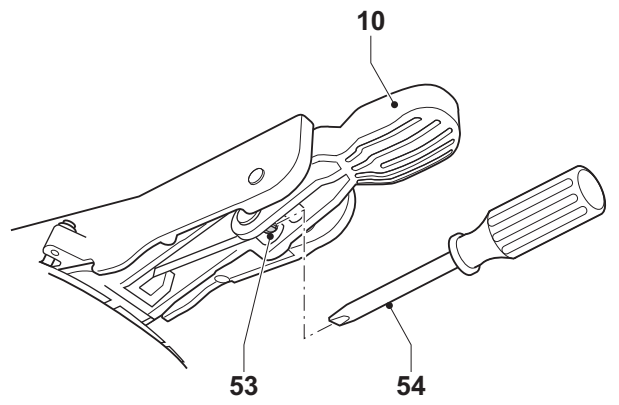

I

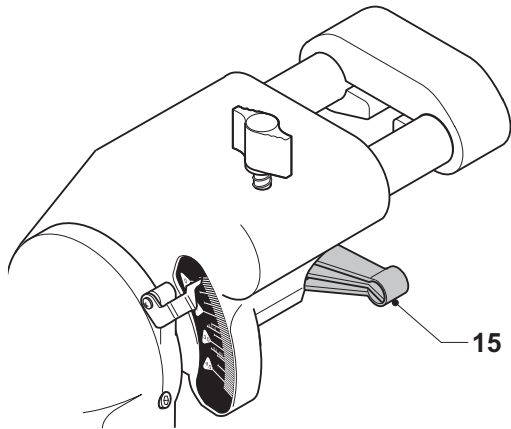

J1

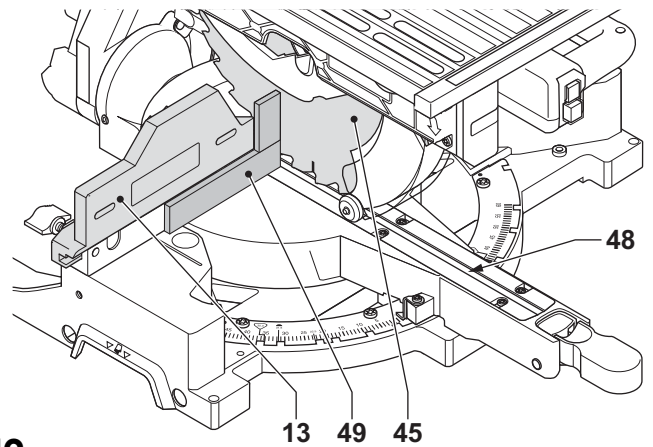

J2

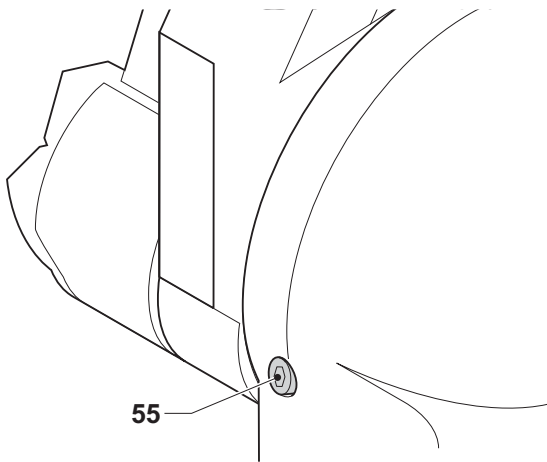

J3

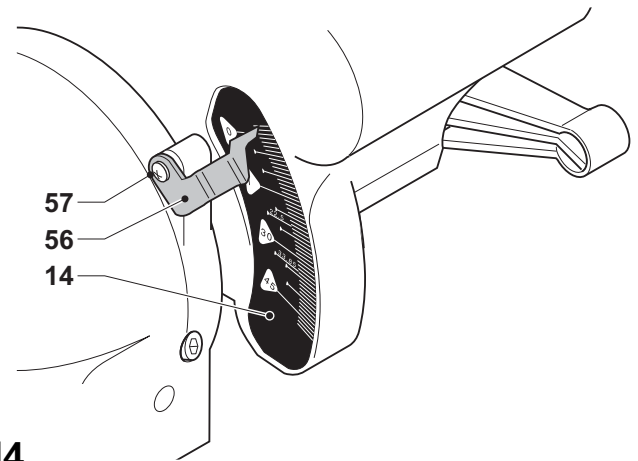

J4

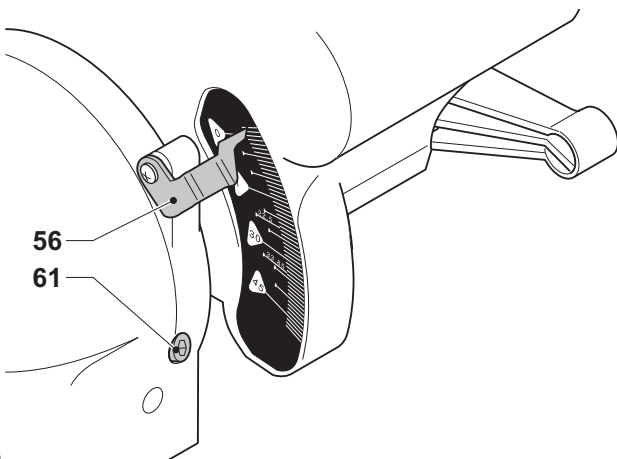

J5

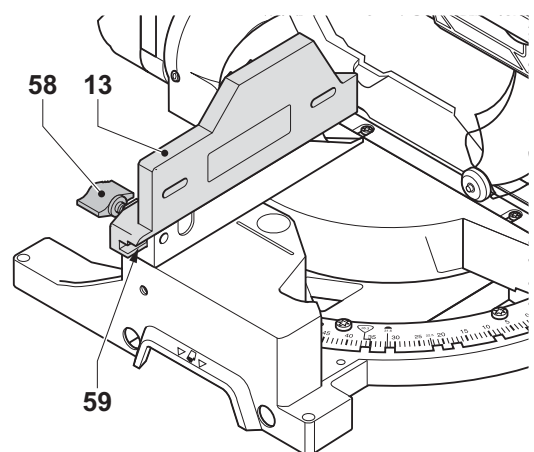

K1

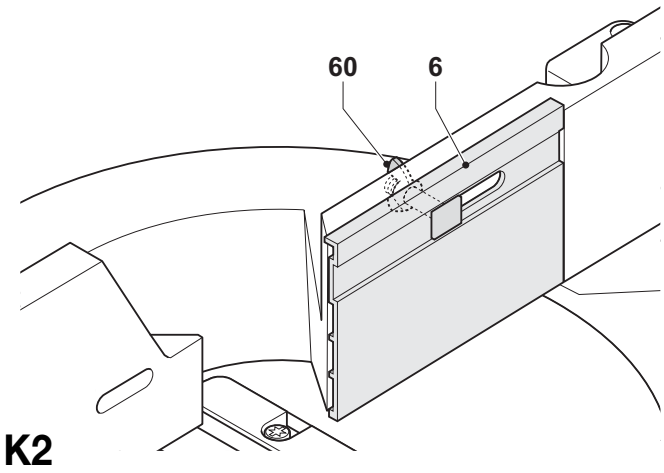

K2

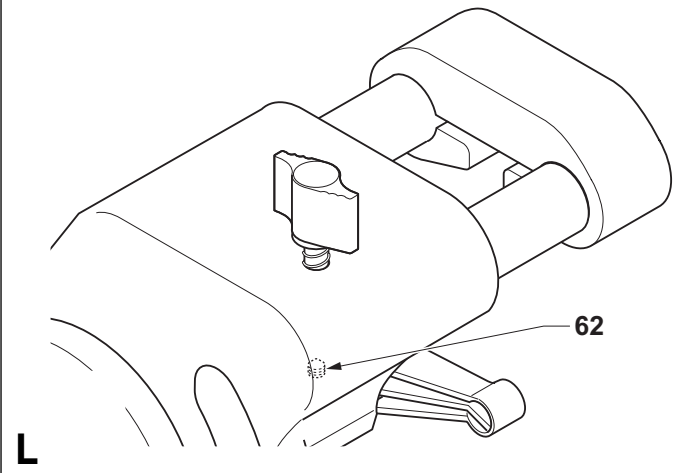

L

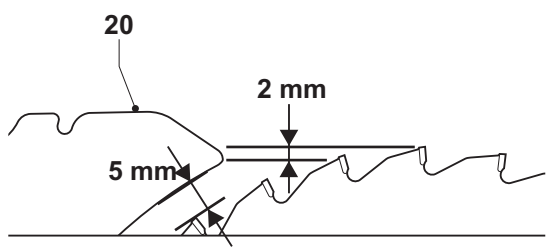

M1

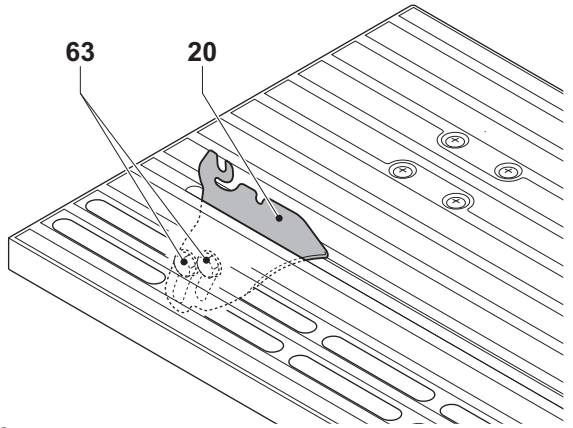

M2

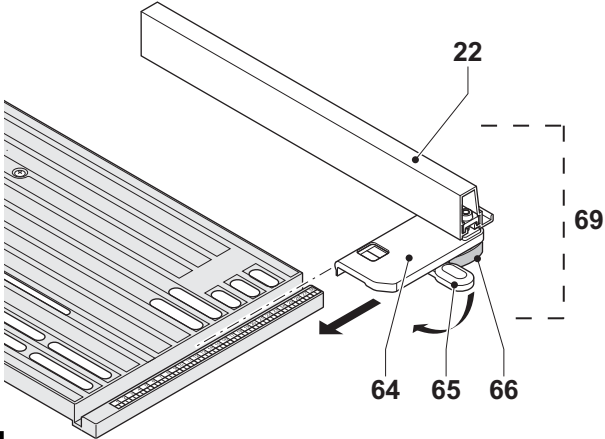

N1

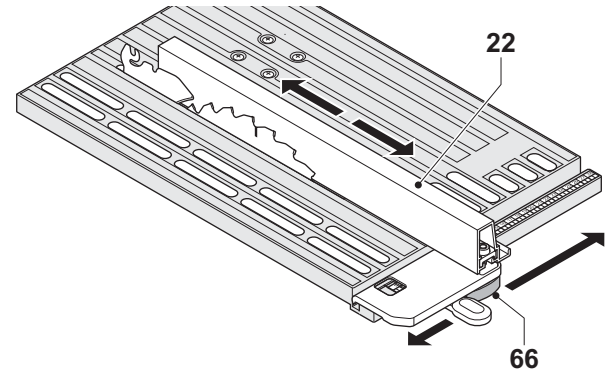

N2

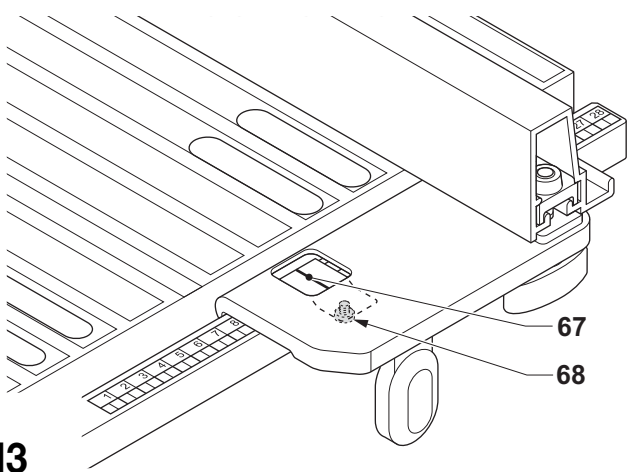

N3

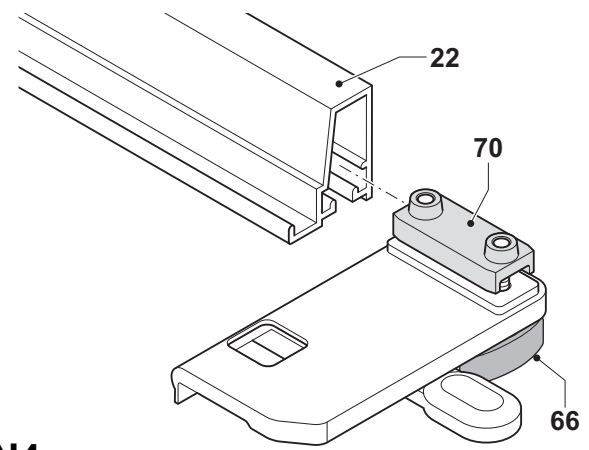

N4

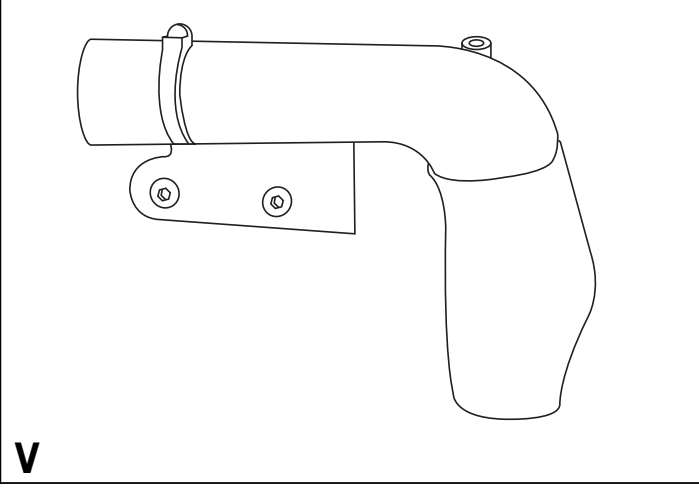
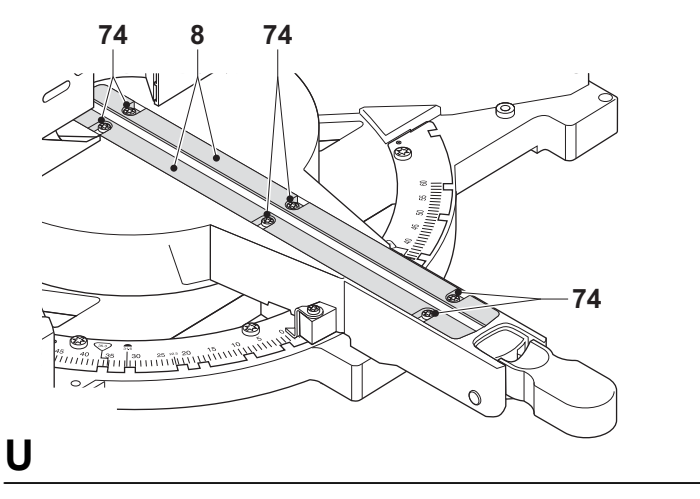
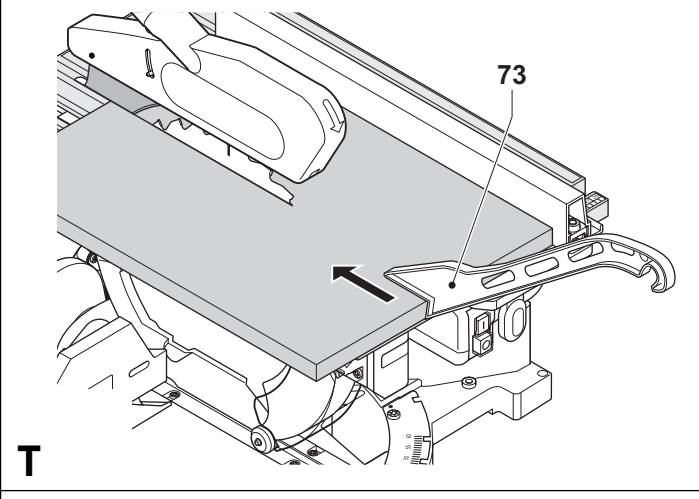
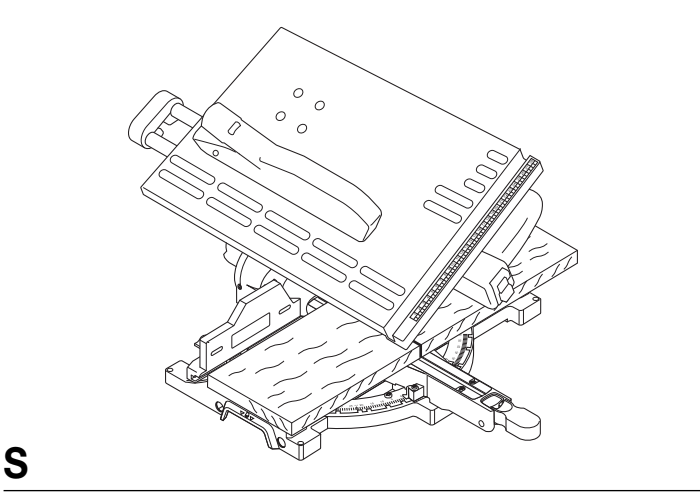
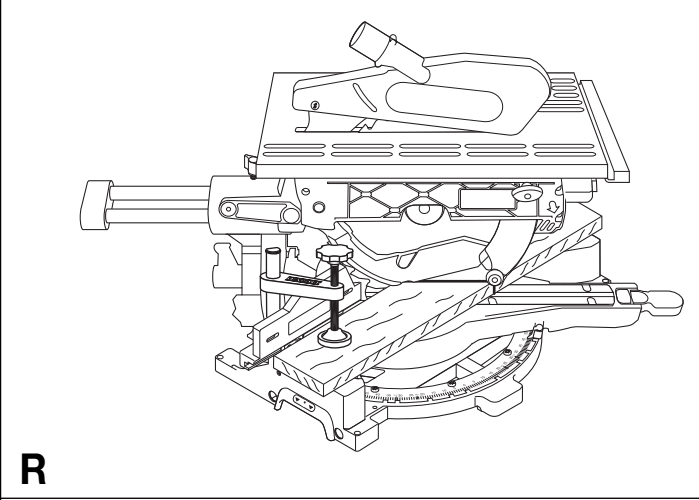
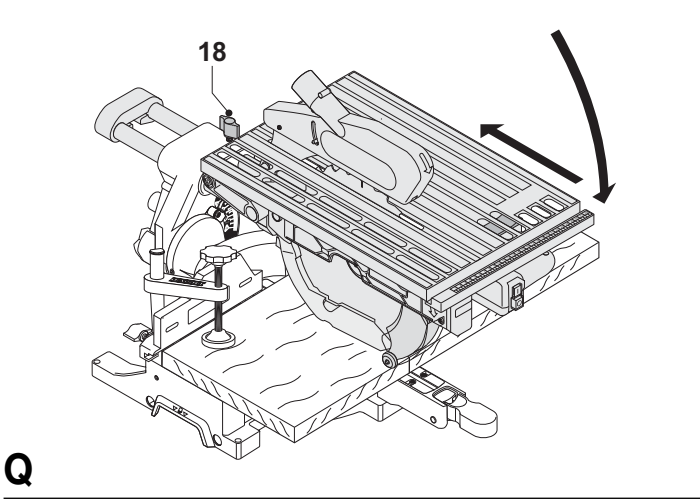
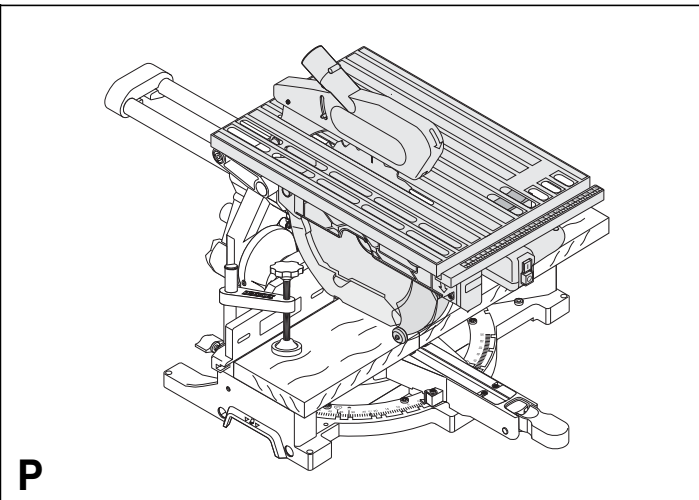
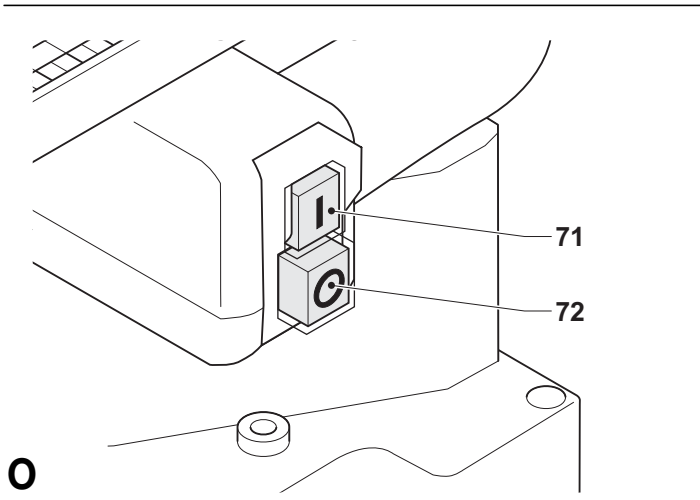

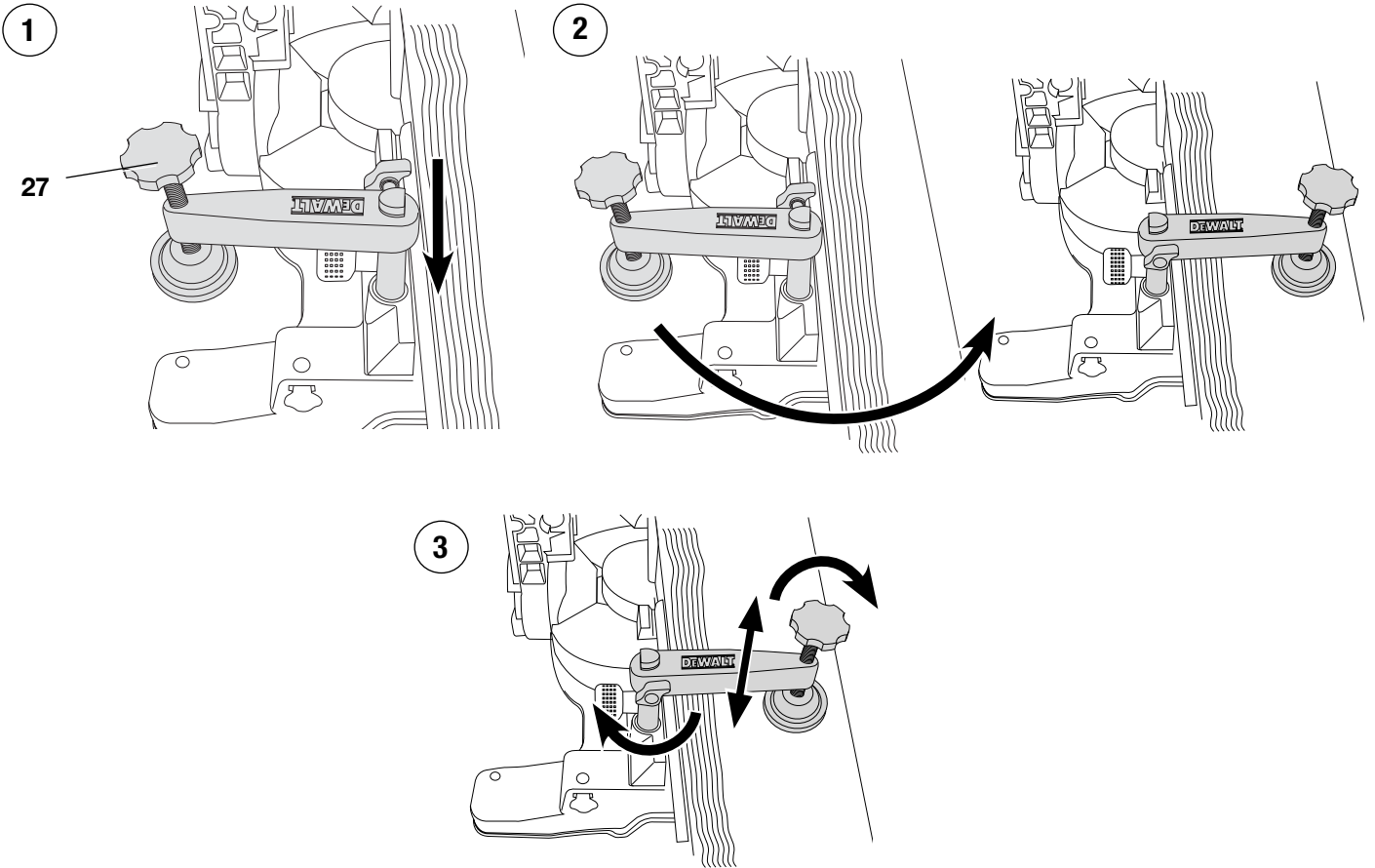

W

TABLE TOP MITRE SAW

D27111/D27112

Congratulations!

You have chosen a DEWALT tool. Years of experience, thorough product development and innovation make DEWALT one of the most reliable partners for professional power tool users.

Technical Data

		D27111	D27112	D27112-LX
Voltage	V	230	230	115
Type		2	2	2
Power input	W	1500	1600	1600
Power output	W	1,100	933	869
Max. blade speed	min ⁻¹	2950	3300	3300
Blade diameter	mm	305	305	305
Blade bore	mm	30	30	30
Blade body thickness	mm	1.8	1.8	1.8
Riving knife thickness	mm	2	2	2
Riving knife hardness		43 ± 5	43 ± 5	43 ± 5
Blade stopping time	s	< 10.0	< 10.0	< 10.0
Weight	kg	26.5	24	24

Cutting capacities

Mitre saw mode				
Mitre (max. positions)	left	50°	50°	50°
	right	60°	60°	60°
Bevel (max. positions)	left	48°	48°	48°
	right	0°	0°	0°
Maximum cross-cut capacity at 90°/90°	mm	220 x 90	285 x 90	285 x 90
Max. width of cut at 45° mitre at max. height 90 mm	mm	155	201	201
Max. width of cut at 45° bevel at max. height 50 mm	mm	220	285	285

Saw bench mode				
Max. depth of cut	mm	0-51	0-51	0-51

L _{PA} (sound pressure)	dB(A)	95.0	97.0	97.0
K _{PA} (sound pressure uncertainty K)	dB(A)	3.1	2.9	2.9
L _{WA} (sound power)	dB(A)	107.0	109.0	109.0
K _{WA} (sound power uncertainty K)	dB(A)	3.0	3.1	3.0

Vibration total values (triax vector sum) determined according to EN 61029-1, EN 61029-2-11:

Vibration emission value a _h				
a _h =	m/s ²	1.3	1.3	1.3
Uncertainty K =	m/s ²	1.5	1.5	1.5

The vibration emission level given in this information sheet has been measured in accordance with a standardised test given in EN 61029 and may be used to compare one tool with another. It may be used for a preliminary assessment of exposure.



WARNING: The declared vibration emission level represents the main applications of the tool. However if the tool is used for different applications, with different accessories or poorly maintained, the vibration emission may differ. This may significantly increase the exposure level over the total working period.

An estimation of the level of exposure to vibration should also take into account the times when the tool is switched off or when it is running but not actually doing the job. This may significantly reduce the exposure level over the total working period.

Identify additional safety measures to protect the operator from the effects of vibration such as: maintain the tool and the accessories, keep the hands warm, organisation of work patterns.

Fuses		
Europe	230 V tools	10 Amperes, mains
U.K. & Ireland	230 V tools	13 Amperes, in plugs
U.K. & Ireland	115 V tools	16 Amperes, mains

NOTE: This device is intended for the connection to a power supply system with maximum permissible system impedance Z_{max} of 0.32 Ω at the interface point (power service box) of user's supply.

The user has to ensure that this device is connected only to a power system which fulfils the requirement above. If necessary, the user can ask the public power supply company for the system impedance at the interface point.

Definitions: Safety Guidelines

The definitions below describe the level of severity for each signal word. Please read the manual and pay attention to these symbols.



DANGER: Indicates an imminently hazardous situation which, if not avoided, **will** result in **death or serious injury**.



WARNING: Indicates a potentially hazardous situation which, if not avoided, **could** result in **death or serious injury**.



CAUTION: Indicates a potentially hazardous situation which, if not avoided, **may** result in **minor or moderate injury**.



NOTICE: Indicates a practice **not related to personal injury** which, if not avoided, **may** result in **property damage**.



Denotes risk of electric shock.



Denotes risk of fire.

EC-Declaration of Conformity

MACHINERY DIRECTIVE



D27111/D27112

DEWALT declares that these products described under **Technical Data** are in compliance with:

2006/42/EC, EN 61029-1, EN 61029-2-11.

These products also comply with Directive 2004/108/EC and 2011/65/EU. For more information, please contact DEWALT at the following address or refer to the back of the manual.

The undersigned is responsible for compilation of the technical file and makes this declaration on behalf of DEWALT.

Horst Grossmann
Vice President Engineering and Product Development
DEWALT, Richard-Klinger-Straße 11,
D-65510, Idstein, Germany
01.01.2012

Safety Instructions



WARNING! When using electric tools basic safety precautions should always be followed to reduce the risk of fire, electric shock and personal injury including the following.

Read all these instructions before attempting to operate this product and save these instructions.

SAVE THIS MANUAL FOR FUTURE REFERENCE

General Safety Rules

1. Keep work area clear.

Cluttered areas and benches invite injuries.

2. Consider work area environment.

Do not expose the tool to rain. Do not use the tool in damp or wet conditions. Keep the work area well lit (250 - 300 Lux). Do not use the tool where there is a risk of causing fire or explosion, e.g., in the presence of flammable liquids and gases.

3. Guard against electric shock.

Avoid body contact with earthed surfaces (e.g., pipes, radiators, cookers and refrigerators). When using the tool under extreme conditions (e.g., high humidity, when metal swarf is being produced, etc.), electric safety can be improved by inserting an isolating transformer or a (FI) earth-leakage circuit-breaker.

4. Keep other persons away.

Do not let persons, especially children, not involved in the work, touch the tool or the extension cord and keep them away from the work area.

5. Store idle tools.

When not in use, tools must be stored in a dry place and locked up securely, out of reach of children.

6. Do not force the tool.

It will do the job better and safer at the rate to which it was intended.

7. Use the right tool.

Do not force small tools to do the job of a heavy duty tool. Do not use tools for purposes not intended; for example do not use circular saws to cut tree limbs or logs.

8. Dress properly.

Do not wear loose clothing or jewellery, as these can be caught in moving parts. Non-skid footwear is recommended when working outdoors. Wear protective hair covering to contain long hair.

9. Use protective equipment.

Always use safety glasses. Use a face or dust mask if working operations create dust or flying particles. If these particles might be considerably hot, also wear a heat-resistant apron. Wear ear protection at all times. Wear a safety helmet at all times.

10. Connect dust extraction equipment.

If devices are provided for the connection of dust extraction and collecting equipment, ensure these are connected and properly used.

11. Do not abuse the cord.

Never yank the cord to disconnect it from the socket. Keep the cord away from heat, oil and sharp edges. Never carry the tool by its cord.

12. Secure work.

Where possible use clamps or a vice to hold the work. It is safer than using your hand and it frees both hands to operate the tool.

13. Do not overreach.

Keep proper footing and balance at all times.

14. Maintain tools with care.

Keep cutting tools sharp and clean for better and safer performance. Follow instructions for lubricating and changing accessories. Inspect tools periodically and if damaged have them repaired by an authorized service facility. Keep handles and switches dry, clean and free from oil and grease.

15. Disconnect tools.

When not in use, before servicing and when changing accessories such as blades, bits and cutters, disconnect tools from the power supply.

16. Remove adjusting keys and wrenches.

Form the habit of checking to see that adjusting keys and wrenches are removed from the tool before operating the tool.

17. Avoid unintentional starting.

Do not carry the tool with a finger on the switch. Be sure that the tool is in the "off" position before plugging in.

18. Use outdoor extension leads.

Before use, inspect the extension cable and replace if damaged. When the tool is used outdoors, use only extension cords intended for outdoor use and marked accordingly.

19. Stay alert.

Watch what you are doing. Use common sense. Do not operate the tool when you are tired or under the influence of drugs or alcohol.

20. Check for damaged parts.

Before use, carefully check the tool and mains cable to determine that it will operate properly and perform its intended function. Check for alignment of moving parts, binding of moving parts, breakage of parts, mounting and any other conditions that may affect its operation. A guard or other part that is damaged should be properly repaired or replaced by an authorized service centre unless otherwise indicated in this instruction manual. Have defective switches replaced by an authorized service centre.

Do not use the tool if the switch does not turn it on and off. Never attempt any repairs yourself.



WARNING! The use of any accessory or attachment or performance of any operation with this tool other than those recommended in this instruction manual may present a risk of personal injury.

21. Have your tool repaired by a qualified person.

This electric tool complies relevant safety rules. Repairs should only be carried out by qualified persons using original spare parts; otherwise this may result in considerable danger to the user.

Additional Safety Rules for Table Top Mitre Saws

- This machine is equipped with a specially configured power supply cord (type M attachment). If the power supply cord is damaged or otherwise defective, it must only be replaced by the manufacturer or by an authorized repair agent.
- Make sure all locking knobs and clamp handles are tight before starting any operation.
- Never use the saw without the guards in position, especially after a mode change. Ensure the guards are in good working order and properly maintained.
- Never place either hand in the blade area when the saw is connected to the electrical power source.
- Never attempt to stop a machine in motion rapidly by jamming a tool or other means against the blade; serious accidents can be caused unintentionally in this way.
- Before using any accessory consult the instruction manual. The improper use of an accessory can cause damage.
- Select the correct blade for the material to be cut.
- Ensure the speed marked on the saw blade is at least equal to the speed marked on the rating plate.
- Wear suitable gloves when handling saw blade and rough materials.
- Ensure that the saw blade is mounted correctly before use.
- Make sure that the blade rotates in the correct direction. Keep the blade sharp.
- Do not use blades of larger or smaller diameter than recommended. Do not use any spacers to make the blade fit onto the spindle. For the proper blade rating refer to the **technical data**. Use only the blades specified in this manual, complying with EN 847-1.
- Consider applying specially designed noise-reduction blades.
- Do not use saw blades manufactured from HIGH SPEED STEEL (HSS).
- Do not use saw blades which are damaged, cracked or deformed.

- Raise the blade from the kerf in the workpiece prior to releasing the switch.
- Do not wedge anything against the fan to hold the motor shaft.
- The blade guard on your saw will automatically raise when the arm is brought down; it will lower over the blade when the arm is raised. The guard can be raised by hand when installing or removing saw blades or for inspection of the saw. Never raise the blade guard manually unless the saw is switched off.
- Keep the surrounding area of the machine well maintained and free of loose materials, e.g. chips and cut-offs.
- Periodically check that the motor air slots are clean and free of chips.
- Disconnect the machine from the mains before carrying out any maintenance work or when changing the blade.
- When possible, always mount the machine to a bench.
- When performing mitre, bevel or compound mitre cuts, adjust the sliding mitre fence to ensure the correct clearance for the application.
- Refrain from removing any cut-offs or other parts of the workpiece from the cutting area while the saw is running.
- Before work checks that the machine is placed on an even surface with sufficient stability.
- Never cut light alloy, especially magnesium.
- Do not use any abrasive or diamond discs.
- In case of an accident or machine failure, immediately turn the machine off and disconnect machine from the power source.
- Report the failure and mark the machine in suitable form to prevent other people from using the defective machine.
- When the saw blade is blocked due to abnormal feed force during cutting, turn the machine off and disconnect it from power supply. Remove the workpiece and ensure that the saw blade runs free. Turn the machine on and start new cutting operation with reduced feed force.
- Ensure that your position is always left or right of the cutting line.
- Provide adequate general or localized lighting
- Ensure the operator is adequately trained in use, adjustment and operation of the machine.
- Turn the machine off when unattended.
- Connect the saw to a dust collection when sawing wood. Always consider factors influencing exposure of dust such as:
 - type of material to be machined (chip board produces more dust than wood);
 - correct adjustment of saw blade;
 - ensure that the local extraction as well as hoods, baffles and chutes are properly adjusted;
 - dust extractor with air velocity not less than 20 m/s
- Be sure all blade and flanges are clean and the recessed sides of the collar are against the blade. Tighten the arbor nut securely.
- Use only saw blades that are sharp and well maintained.
- Do not attempt to operate on anything but the designated voltage
- Do not apply lubricants to the blade when it is running.
- Ensure that bystanders do not stand behind the machine.
- For your own safety always mount the machine to a work bench using bolts with a diameter of 8 mm and 80 mm in length.

Additional Safety Rules for Table Saw Mode

- Replace the table insert when worn.
- When performing vertical straight cross-cuts, adjust the sliding fence correctly to ensure a clearance of max. 5 mm between the saw blade and the fence.
- Never use your saw without the table insert.
- Never cut when riving knife and/or upper guard are removed.
- Always use the push stick. Never cut workpieces smaller than 30 mm.

- Without additional support, the machine is designed to accept the maximum workpiece size of:
 - Height 51 mm by width 500 mm by length 700 mm
 - Longer workpieces need to be supported by suitable additional table.
- The riving knife shall not be thicker than the width of the groove cut by the saw blade and not thinner than the body of the saw blade.
- Make sure that the blade rotates in the correct direction and that the teeth are pointing to the front of the saw bench.
- Be sure all clamp handles are tight before starting any operation.
- Make sure that the riving knife is adjusted to the correct distance from the blade – maximum 5 mm.
- Keep your hands out of the path of the saw blade.
- Disconnect the saw from the mains supply before changing blades or carrying out maintenance.
- Use a push stick at all times and never place hands closer than 150 mm from the saw blade while cutting.
- Do not reach around behind the saw blade.
- Always keep the push stick in its place when not in use.
- Do not stand on top of the unit.
- During transportation, make sure that the upper part of the saw blade is covered, e.g. the guard.
- Do not use the upper guard for handling or transportation.
- Adjust the sliding fence correctly to avoid contact with the upper guard.
- Ensure that the table is securely fixed.
- Do not use the saw for cutting any material other than wood.
- Slotting, rebating or grooving is not allowed.
- Ensure that the arm is securely fixed when sawing in the bench saw mode. Only use the machine when the saw bench table is in horizontal position.

Mitre Saw Mode

- Ensure that the arm is securely fixed when performing bevel cuts.
- Never perform any cleaning or maintenance work when the machine is running and the saw head is not in the rest position.
- Ensure that the upper portion of the saw blade is securely fixed at the chosen height. Never remove the upper blade guard when using the machine in mitre saw mode.
- Never cut workpieces shorter than 160 mm.
- Without additional support, the machine is designed to accept the maximum workpiece size of:

D27111

- Height 90 mm by width 220 mm by length 550 mm.

D27112

- Height 90 mm by width 285 mm by length 550 mm.
- Longer workpieces need to be supported by suitable additional table.
- Always clamp the workpiece safely.

Residual risks

The following risks are inherent to the use of saws:

- injuries caused by touching the rotating parts

In spite of the application of the relevant safety regulations and the implementation of safety devices, certain residual risks cannot be avoided. These are:

- Impairment of hearing.
- Risk of accidents caused by the uncovered parts of the rotating saw blade.
- Risk of injury when changing the blade.
- Risk of squeezing fingers when opening the guards.
- Health hazards caused by breathing dust developed when sawing wood, especially oak, beech and MDF.

- Risk of injury caused by parts of the workpiece hurled at bystanders.
- Risk of accidents caused by flying metal particles when cutting into the fence.
- Fire hazard due to extreme dust concentration when not cleaned regularly.
- Risk of uncontrolled situations when used in ambient temperatures below -10 °C or above +45 °C.

The following factors are of influence to noise production:

- the material to be cut
- the type of saw blade
- the feed force

The following factors are of influence to dust exposure:

- worn saw blade
- dust extractor with air velocity less than 20 m/s
- workpiece not exactly guided

Markings on Tool

The following pictograms are shown on the tool:



Safe use warning



Read the instruction manual before use



When using in bench saw mode, ensure upper and lower guards are in place and well functioning. Never operate the machine when the bench table is not in horizontal position.



When using in mitre saw mode, make sure that the upper guard is in place and functioning properly. Ensure the bench saw table is in its highest position.



When making a sliding cut in mitre saw mode, observe the instructions as provided under **Performing a sliding cut**.



Carrying point.

DATE CODE POSITION (FIG. A2)

The Date Code (76), which also includes the year of manufacture, is printed into the housing.

Example:

2012 XX XX
Year of Manufacture

Package Contents

The package contains:

- 1 Table top mitre saw
- 1 Saw blade
- 1 Parallel rip fence
- 1 Upper blade guard
- 1 Push stick
- 1 Dust collection port (fig. V)
- 1 T30 star wrench
- 1 T40 star wrench
- 1 Material clamp
- 1 Instruction manual
- 1 Exploded drawing

- Check for damage to the tool, parts or accessories which may have occurred during transport.
- Take the time to thoroughly read and understand this manual prior to operation.

Description (fig. A1 - A4)



WARNING: Never modify the power tool or any part of it. Damage or personal injury could result.

Fig. A1

- 1 On/off switch
- 2 Operating handle
- 3 Head lock up release lever
- 4 Additional saw bench table locking knob
- 5 Moveable front lower blade guard
- 6 Fence right-hand side
- 7 Fixed table
- 8 Kerf plate
- 9 Mitre latch
- 10 Mitre lever
- 11 Rotating table/mitre arm
- 12 Mitre scale
- 13 Fence left-hand side
- 14 Bevel scale
- 15 Bevel clamp handle
- 16 Saw bench table locking knob
- 17 Head lock down pin
- 18 Rail lock knob

Fig. A2

- 19 Saw bench table
- 20 Riving knife
- 21 Upper blade guard
- 22 Parallel rip fence
- 23 Push stick location
- 24 Moveable rear lower blade guard
- 25 Attachment mounting holes
- 26 Hand indentation
- 76 Date code

Optional accessories

Fig. A3

- 27 Material clamp

Fig. A4

- 28 Legstand

INTENDED USE

Your D27111/D27112 table top mitre saw has been developed for professional applications. This high precision machine can be easily and quickly set to crosscut, bevel, mitre, or compound mitre.

This unit is designed for use with a nominal blade diameter 305 mm carbide tip blade for professional applications.

DO NOT use under wet conditions or in presence of flammable liquids or gases.

These table top mitre saws are professional power tools.

DO NOT let children come into contact with the tool. Supervision is required when inexperienced operators use this tool.



WARNING! Do not use the machine for purposes other than intended.

- This product is not intended for use by persons (including children) suffering from diminished physical, sensory or mental abilities; lack of experience, knowledge or skills unless they are supervised by a person responsible for their safety. Children should never be left alone with this product.

Electrical Safety

The electric motor has been designed for one voltage only. Always check that the power supply corresponds to the voltage on the rating plate.

D27111

This machine is of class I construction, therefore earthed (grounded) connection is required.

D27112



Your DEWALT tool is double insulated in accordance with EN 61029; therefore no earth wire is required.



WARNING: 115 V units have to be operated via a fail-safe isolating transformer with an earth screen between the primary and secondary winding.

If the supply cord is damaged, it must be replaced by a specially prepared cord available through the DEWALT service organisation.

Mains Plug Replacement (U.K. & Ireland Only)

If a new mains plug needs to be fitted:

- Safely dispose of the old plug.
- Connect the brown lead to the live terminal in the plug.
- Connect the blue lead to the neutral terminal.
- Connect the green/yellow lead to the earth terminal (D27111 only)



WARNING: No connection is to be made to the earth terminal (D27112 only).

Follow the fitting instructions supplied with good quality plugs.
Recommended fuse: 13 A.

Fitting a mains plug to 115 V units (U.K. and Ireland only)

The plug should be fitted by a competent person. If you are in doubt, contact an authorized DEWALT repair agent or a qualified electrician.

The plug fitted should comply with BS EN 60309 (BS4343) 16Amps, earthing contact position 4h.

Using an Extension Cable

If an extension cable is required, use an approved 3-core extension cable suitable for the power input of this tool (see **Technical Data**). The minimum conductor size is 1.5 mm²; the maximum length is 30 m.

When using a cable reel, always unwind the cable completely.

ASSEMBLY



WARNING: To reduce the risk of injury, turn unit off and disconnect machine from power source before installing and removing accessories, before adjusting or changing set-ups or when making repairs. Be sure the trigger switch is in the OFF position. An accidental start-up can cause injury.

Unpacking (fig. B)

- Remove the saw from the packaging material carefully.
- Release the rail lock knob (18), and push the saw head back to lock it in the rear position.
- Lock the table (19) into highest position.
- Press down the operating handle (2) and pull out the lock down pin (17), as shown.
- Gently release the downward pressure and allow the head to rise to its full height.

Bench mounting (fig. C)

- Holes (36) are provided in all four feet to facilitate bench mounting. Two different sized holes are provided to accommodate different sizes of bolts. Use either hole; it is not necessary to use both. Bolts with a diameter of 8 mm and 80 mm in length is suggested. Always mount your saw firmly to prevent movement. To enhance the portability, the tool can be mounted to a piece of 12.5 mm or thicker plywood which can then be clamped to your work support or moved to other job sites and reclamped.
- When mounting your saw to a piece of plywood, make sure that the mounting screws do not protrude from the bottom of the wood. The plywood must sit flush on the work support. When clamping the saw to any work surface, clamp only on the clamping bosses where the mounting screw holes are located. Clamping at any other point will interfere with the proper operation of the saw.
- To prevent binding and inaccuracy, be sure the mounting surface is not warped or otherwise uneven. If the saw rocks on the surface, place a thin piece of material under one saw foot until the saw is firm on the mounting surface.

Storing the fastener tools (fig. D)

The following tools are supplied with the machine:

- 1 T30 star wrench (37)
- 1 T40 star wrench (38)

- Take care to store the tools each time after they have been used in assembly or adjustment.

Mounting the upper blade guard (fig. E)

The upper blade guard (21) is designed to be quickly and easily attached to the riving knife (20) once the machine has been set up for saw bench mode.

- Loosen the bolt (39) and leave nut (40) in the hexagonal pocket.
- Holding the guard vertically, align the slot in the rear of the guard with the riving knife.
- Lower the guard over the riving knife (20), making sure the shaft of the bolt enters the recess.
- Turn the guard into horizontal position, which will lock the guard to the riving knife.
- Insert bolt (39) into the hole and tighten with special torx wrench.

Mounting the saw blade (fig. D & F1 - F5)



WARNING: To reduce the risk of injury, turn unit off and disconnect machine from power source before installing and removing accessories, before adjusting or changing set-ups or when making repairs. Be sure the trigger switch is in the OFF position. An accidental start-up can cause injury.



WARNING: The teeth of a new blade are very sharp and can be dangerous.



WARNING: After mounting or replacing the blade, always check that the blade is fully covered by the guard.



WARNING! Be aware the saw blade shall be replaced in the described way only. Only use saw blades as specified under **Technical Data**; Cat.no.: DT4350 is suggested.

In order to fit a new saw blade it is necessary to adjust the table into highest position and raise the saw head to its highest position.

D27111

- Insert the T30 star wrench (37) through the hole (42) in the casing into the spindle end (fig. F1). Place the T40 star wrench (38) into the blade locking screw (43) (fig. F3).
- The blade locking screw has a left-handed thread, therefore holding the key firmly, turn clockwise to loosen.
- Depress the head lock up release lever (3) to release the lower guard (5 & 23), then raise the lower guard as far as possible (fig. F4).

- Remove the blade locking screw (43) and the outside arbor collar (44) (fig. F5).
- Make sure the inner flange and both faces of the blade are clean and free of dust.
- Install the saw blade (45) onto the shoulder (46) provided on the inside arbor collar (47), making sure that the teeth at the bottom edge of the blade are pointing toward the back of the saw (away from the operator).
- Carefully ease the blade into position and release the lower blade guard.
- Replace the outer arbor collar.
- Tighten the blade locking screw (43) by turning counterclockwise while holding the star wrench steady with your other hand.
- Place the star wrench in their storage position (fig. D).

D27112

- Press spindle lock button (75) to lock saw blade into position (fig. F2).
- Insert T40 star wrench (38) into the blade locking screw (43) (fig. F3).
- The blade locking screw has a left-handed thread, therefore holding the key firmly, turn clockwise to loosen.
- Depress the head lock up release lever (3) to release the lower guard (5 & 23), then raise the lower guard as far as possible (fig. F4).
- Remove the blade locking screw (43) and the outside arbor collar (44) (fig. F5).
- Make sure the inner flange and both faces of the blade are clean and free of dust.
- Install the saw blade (45) onto the shoulder (46) provided on the inside arbor collar (47), making sure that the teeth at the bottom edge of the blade are pointing toward the back of the saw (away from the operator).
- Carefully ease the blade into position and release the lower blade guard.
- Replace the outer arbor collar.
- Tighten the blade locking screw (43) by turning counterclockwise while holding the spindle lock button (75).
- Place the star wrench in the storage position (fig. F2).

Adjustment



WARNING: To reduce the risk of injury, turn unit off and disconnect machine from power source before installing and removing accessories, before adjusting or changing set-ups or when making repairs. Be sure the trigger switch is in the OFF position. An accidental start-up can cause injury.

Adjusting the saw blade (fig. F5)

If the saw blade is wobbling during start up and run down, then adjust as follows.

- Loosen the screw for the arbor collar (44) and rotate the blade (45) a quarter turn.
- Retighten the screw and check to see if the blade has any wobble.
- Repeat these steps until the blade wobble has been eliminated.

Adjustments for mitre saw mode

Your mitre saw was accurately adjusted at the factory. If readjustment due to shipping and handling or any other reason is required, follow the steps below to adjust your saw. Once made, these adjustments should remain accurate.

Checking and adjusting the blade to the fence (fig. G1 - G4)

- Release the mitre lever (10) and depress the mitre latch (9) to release the mitre arm (11).
- Swing the mitre arm until the latch locates it at the 0° mitre position. Do not tighten the lever.
- Pull down the head until the blade just enters the saw kerf (48).
- Place a square (49) against the left side (13) of the fence and blade (45) (fig. G3).



WARNING: Do not touch the tips of the blade teeth with the square.

- If adjustment is required, proceed as follows:
- Loosen the screws (50) and move the scale/mitre arm assembly left or right until the blade is at 90° to the fence as measured with the square.
- Retighten the screws (50). Pay no attention to the reading of the mitre pointer at this point.

Adjusting the mitre pointer (fig. G1, G2 & H)

- Release the mitre lever (10) and depress the mitre latch (9) to release the mitre arm (11).
- Move the mitre arm to set the mitre pointer (51) to the zero position, as shown in fig. H.
- With the mitre lever loose, allow the mitre latch to snap into place as you rotate the mitre arm past zero.
- Observe the pointer (51) and mitre scale (12). If the pointer does not indicate exactly zero, loosen the screw (52), move the pointer to read 0° and tighten the screw.

Mitre lock/detent rod adjustment (fig. I)

If the base of the saw can be moved while the mitre lever (10) is locked, the mitre lock/detent rod (53) must be adjusted.

- Unlock the mitre lever (10).
- Fully tighten the mitre lock/detent rod (53) using a screwdriver (54). Then loosen the rod a quarter of a turn.
- Check that the table does not move when the lever (10) is locked at a random (not preset) angle.

Checking and adjusting the blade to the table (fig. J1 - J4)

- Loosen the bevel clamp handle (15).
- Press the saw head to the right to ensure it is fully vertical and tighten the bevel clamp handle.
- Pull down the head until the blade just enters the saw kerf (48).
- Place a set square (49) on the table and up against the blade (45) (fig. J2).



WARNING: Do not touch the tips of the blade teeth with the square.

- If adjustment is required, proceed as follows:
- Loosen the bevel clamp handle (15) and turn the vertical position adjustment stop screw (55) in or out until the blade is at 90° to the table as measured with the square.
- If the bevel pointer (56) does not indicate zero on the bevel scale (14), loosen the screw (57) that secures the pointer and move the pointer as necessary.

Adjusting the fence (fig. K1 & K2)

The upper part of the left side of the fence can be adjusted to the left to provide clearance, allowing the saw to bevel to a full 45° left. To adjust the fence (13):

- Loosen the plastic knob (58) and slide the fence to the left.
- Make a dry run with the saw switched off and check for clearance. Adjust the fence to be as close to the blade as practical to provide maximum workpiece support, without interfering with the up and down movement of the arm.
- Tighten the knob securely.



WARNING: The guide groove (59) can become clogged with sawdust. Use a stick or some low pressure air to clear the guide groove.

The moveable part of the right side of the fence can be adjusted to provide maximum support of the workpiece near the blade, while allowing the saw to bevel to a full 45° left. The sliding distance is limited by stops in both directions. To adjust the fence (6):

- Loosen the wingnut (60) to release the fence (6).
- Slide the fence to the left.
- Make a dry run with the saw switched off and check for clearance. Adjust the fence to be as close to the blade as practical to provide maximum workpiece support, without interfering with the up and down movement of the arm.
- Tighten the wingnut (60) to secure the fence in place.

Checking and adjusting the bevel angle (fig. J1, J5 & K1)

- Loosen the left side fence clamping knob (58) and slide the upper part of the left side fence to the left as far as it will go.
- Loosen the bevel clamp handle (15) and move the saw head to the left. This is the 45° bevel position.
- If adjustment is required, proceed as follows:
- Turn the stopscrew (61) in or out as necessary until the pointer (56) indicates 45°.



WARNING: While performing this adjustment, it is advisable to take the weight of the saw head by holding it. This will make it easier to turn the adjustment screw.

Rail guide adjustment (fig. L)

- Regularly check the rails for clearance.
- To reduce clearance, gradually rotate the set screw (62) clockwise while sliding the saw head back and forth.

Adjustments for saw bench mode

Changing from mitre saw to saw bench mode (fig. A1 & A2)

- Lock the table (19) into highest position.
- Put the blade into 0° cross-cut position with the mitre lever (10) secured (fig. A1).
- Lock the rail lock knob (18) with the saw head in the rear position.
- Press the head lock-up release lever (3) to lower the head and depress the lock down pin (17).
- Fit the parallel fence (22) as described below.

Adjusting the riving knife (fig. M1 & M2)

The correct position is for the top of the riving knife (20) to be no more than 2 mm below the highest tooth of the blade and the body of the radius to be a maximum of 5 mm from the tips of the saw blade teeth (fig. M1).

- Loosen the bolts (63) which allows the riving knife to move up and down (fig. M2).
- Slide the knife either up or down until the correct position is attained.
- Retighten the bolts (63) firmly.

Mounting and adjusting the parallel fence (fig. N1 - N4)

- Slide the bracket (64) on from the right (fig. N1). The clamping plate engages behind the front edge of the table.
- Slide the fence (22) up against the blade.
- Push the lever (65) down to secure the fence in place.
- Check that the fence is parallel to the blade.
- If adjustment is required, proceed as follows:
- Loosen the adjustment knob (66) fastening the fence bracket to the fence support (fig. N2).
- Adjust the fence so that it is parallel to the blade by checking the distance between the blade and the fence at the front and rear of the blade.

- When the adjustment has been carried out, re-tighten the adjustment knob and check again that the fence is parallel to the blade.
- Check that the pointer (67) indicates zero on the scale (fig. N3). If the pointer does not indicate exactly zero, loosen the screw (68), move the pointer to read 0 and tighten the screw.

The fence is reversible: the workpiece can be guided along the 52 mm or along the 8 mm face to allow the use of a push stick when ripping thin workpieces (fig. N4).

- To set for 8 mm, loosen the adjustment knob (66) and slide the fence (22) out of the clamping support (70).
- Turn the fence and re-engage the clamping support in the slot as shown (fig. N4).
- To use with the full height of 52 mm, slide the fence into the clamping support with the wide face in the vertical position (fig. N1).



WARNING:

- Use the 8 mm profile for ripping low workpieces to allow access between the blade and the fence for the push stick.
- The rear end of the fence should be level with the front of the riving knife.

Adjusting the saw bench table (fig. A1, A2)

The table (19) slides up and down manually and is held at the required height with two locking knobs.

- Loosen the table locking knobs, both main (16) and additional (4), but do not take them off.
- Set the table to the proper height needed.
- Tighten the table locking knobs. First tighten the main knob (16), then secure the table in position with the additional knob (4).

Changing from saw bench to mitre saw mode (fig. A1 & A2)

- Lock the table (19) into highest position.
- Press down the operating handle (2) and pull out the lock down pin (17), as shown.
- Gently release the downward pressure and allow the head to rise to its full height.

Prior to Operation

- Install the appropriate saw blade. Do not use excessively worn blades. The maximum rotation speed of the tool must not exceed that of the saw blade.
- Do not attempt to cut excessively small pieces.
- Allow the blade to cut freely. Do not force.
- Allow the motor to reach full speed before cutting.
- Make sure all locking knobs and clamp handles are tight.
- Secure the workpiece.
- Although this saw will cut wood and many nonferrous materials, these operating instructions refer to the cutting of wood only. The same guidelines apply to the other materials. Do not cut ferrous (iron and steel) materials or masonry with this saw! Do not use any abrasive discs!
- When cutting non-ferrous materials, always use a suitable DEWALT saw blade with a rake angle of -5°. Make sure to secure the material in position using a material clamp.
- Make sure to use the kerf plate. Do not operate the machine if the kerf slot is wider than 10 mm.
- Ensure the material to be sawn is firmly secured in place.
- Apply only a gentle pressure to the tool and do not exert side pressure on the saw blade.
- Avoid overloading.
- Always remove the dust from the machine after use to ensure the lower guard operates properly.
- When sawing wood and wood products, always connect a dust extraction device designed in accordance with the relevant regulations regarding dust emission.

OPERATION

Instructions for Use



WARNING: Always observe the safety instructions and applicable regulations.



WARNING: To reduce the risk of injury, turn unit off and disconnect machine from power source before installing and removing accessories, before adjusting or changing set-ups or when making repairs. Be sure the trigger switch is in the OFF position. An accidental start-up can cause injury.

The attention of UK users is drawn to the "woodworking machines regulations 1974" and any subsequent amendments.

Ensure the machine is placed to satisfy your ergonomic conditions in terms of table height and stability. The machine site shall be chosen so that the operator has a good overview and enough free surrounding space around the machine that allows handling of the workpiece without any restrictions.

To reduce effects of vibration make sure the environment temperature is not too cold, machine and accessory is well maintained and the workpiece size is suitable for this machine.

Switching on and off (fig. O)

The on/off switch has a built-in no-volt release function: should the power be shut off for some reason, the switch has to be deliberately reactivated.

- To switch the machine on, press the green start button (71).
- To switch the machine off, press the red stop button (72).

Basic saw cuts

Quality of cut

The smoothness of any cut depends on a number of variables, e.g. the material being cut. When smoothest cuts are desired for moulding and other precision work, a sharp (60 tooth carbide) blade and a slower, even cutting rate will produce the desired results.



WARNING: Ensure that the material does not creep while cutting; clamp it securely in place. Always let the blade come to a full stop before raising the arm. If small fibres of wood still split out at the rear of the workpiece, stick a piece of masking tape on the wood where the cut will be made. Saw through the tape and carefully remove tape when finished.

Dust extraction (fig. A5)

The machine is provided with a 38 mm dust extraction port on the upper blade guard.

- Connect a suitable dust extraction device, designed in accordance with the relevant regulations regarding dust emission, during all sawing operations.

Sawing in mitre saw mode

It is dangerous to operate without guarding. Guards must be in position when sawing.

General handling

- In the mitre saw mode, the sawhead is automatically locked in the upper "park"-position.
- Squeezing the guard release lever will unlock the sawhead. Moving the sawhead down retracts the movable lower guard.
- Never seek to prevent the lower guard returning to its park position when the cut is completed.
- The D27111 saw can cut workpieces up to 220 mm width by 90 mm height. The D27112 saw can cut workpieces up to 285 mm width by 90 mm height. For the proper cutting capacities, refer to the **technical data**. The length of the workpiece should never exceed the base width

without adequate support. The end of the workpiece should never be less than 160 mm away from the blade without additional clamping means.

- In operation, place your hands no closer than 160 mm from the blade. When cutting short material (min. 160 mm to the left or the right of the blade), the use of the optional material clamp is required.
- The minimum length of offcut material is 10 mm.
- When cutting workpieces longer than the table width, make sure that the workpiece is stable over its full length. Support the protruding parts of the workpiece as necessary, e.g. using the optional workpiece extension.
- When cutting UPVC sections, a supporting piece made out of timber with a complementary profile should be placed beneath the material being cut to provide the correct level of support.

Clamping the Workpiece (fig. A3, W)



WARNING: A workpiece that is clamped, balanced and secure before a cut may become unbalanced after a cut is completed. An unbalanced load may tip the saw or anything the saw is attached to, such as a table or workbench. When making a cut that may become unbalanced, properly support the workpiece and ensure the saw is firmly bolted to a stable surface. Personal injury may occur.



WARNING: The clamp foot must remain clamped above the base of the saw whenever the clamp is used. Always clamp the workpiece to the base of the saw – not to any other part of the work area. Ensure the clamp foot is not clamped on the edge of the base of the saw.



CAUTION: Always use a work clamp to maintain control and reduce the risk of workpiece damage and personal injury.

Use the material clamp (27) provided with your saw. Other aids such as spring clamps, bar clamps or C-clamps may be appropriate for certain sizes and shapes of material.

TO INSTALL CLAMP

1. Insert it into the hole behind the fence. The clamp should be facing toward the back of the mitre saw. Ensure the groove on the clamp rod is fully inserted into the base of the mitre saw. If the groove is visible, the clamp will not be secure.
2. Rotate the clamp 180° toward the front of the mitre saw.
3. Loosen the knob to adjust the clamp up or down, then use the fine adjust knob to firmly clamp the workpiece.

NOTE: Place the clamp on the right side of the base when beveling. ALWAYS MAKE DRY RUNS (UNPOWERED) BEFORE FINISH CUTS TO CHECK THE PATH OF THE BLADE. ENSURE THE CLAMP DOES NOT INTERFERE WITH THE ACTION OF THE SAW OR GUARDS.

Vertical straight cross cut (fig. A1 & P)

- Release the mitre lever (10) and depress the mitre latch (9).
- Engage the mitre latch at the 0° position and tighten the mitre lever.
- Place the wood to be cut against the fence (6 & 13).
- Take hold of the operating handle (2) and depress the head lock up release lever (3) to release the head.
- Switch the machine on and allow the saw blade to reach full speed.
- Depress the head to allow the blade to cut through the timber and enter the plastic kerf plate (8).
- After completing the cut, switch the machine off and wait for the saw blade to come to a complete standstill before returning the head to its upper rest position.

Performing a sliding cut (fig. Q)

The guide rail allows cutting larger workpieces using an out-down-back sliding motion.

- Release the rail lock knob (18).
- Pull the saw head towards you and switch the tool on.
- Lower the saw blade into the workpiece and push the head back to complete the cut.

- Proceed as described above.



WARNING:

- Do not perform sliding cuts on workpieces smaller than 50 x 100 mm.
- Remember to lock the saw head in the rear position when the sliding cuts are finished.

Cutting small pieces (fig. K1 & K2)

The upper part of the left side of the fence (13) and the moveable part of the right side of the fence (6) can be adjusted to provide maximum support when cutting small pieces.

- Put the saw blade into vertical position.
- Loosen the plastic knob (58) at least 3 full turns.
- Adjust the left fence as close to the blade as possible.
- Tighten the knob securely.
- Loosen the wingnut (60).
- Adjust the right fence as close to the blade as possible.
- Tighten the wingnut.

Vertical mitre cross-cut (fig. A1 & R)

- Release the mitre lever (10) and depress the mitre latch (9). Move the arm left or right to the required angle.
- The mitre latch will automatically locate at 10°, 15°, 22.5°, 31.62° and 45° both left and right, and at 50° left and 60° right. If any intermediate angle is required hold the head firmly and lock by tightening the mitre lever.
- Always ensure that the mitre lever is locked tightly before cutting.
- Proceed as for a vertical straight cross-cut.



WARNING: When mitring the end of a piece of wood with a small off-cut, position the wood to ensure that the off-cut is to the side of the blade with the greater angle to the fence:

left mitre, off-cut to the right
right mitre, off-cut to the left.

Bevel cuts (fig. A1, K1 & S)

Bevel angles can be set from 48° left to 2° right and can be cut with the mitre arm set between zero and a maximum of 45° mitre position right or left.

- Loosen the left side fence clamping knob (58) and slide the upper part of the left side fence (13) to the left as far as it will go. Loosen the bevel clamp handle (15) and set the bevel as desired.
- Tighten the bevel clamp handle (15) firmly.
- Proceed as for a vertical straight cross-cut.

Compound mitre

This cut is a combination of a mitre and a bevel cut.

- Set the bevel angle and subsequently set the mitre angle.

Sawing in the bench mode

- Always use the riving knife.
- Always ensure that the riving knife and blade guard are correctly aligned.
- Always ensure that the mitre saw is set and locked in 0° mitre.



WARNING: Do not cut metal in this mode.

Ripping (fig. T)

- Set the bevel angle to 0°.

- Adjust the saw blade height. The correct blade position is to have the tips of three teeth above the top surface of the wood. Ensure that the saw bench table is securely fixed at the chosen height.
- Set the parallel fence to the required distance.
- Hold the workpiece flat on the table and against the fence. Keep the workpiece approx. 25 mm away from the saw blade.
- Keep both hands away from the path of the saw blade.
- Switch the machine on and allow the saw blade to reach full speed.
- Slowly feed the workpiece underneath the upper blade guard, keeping it firmly pressed against the fence. Allow the teeth to cut, and do not force the workpiece through the saw blade. The saw blade speed should be kept constant.
- Remember to use the push stick (73) when close to the blade.
- After completing the cut, switch the machine off, allow the saw blade to stop and remove the workpiece.



WARNING:

- Never push or hold the free or cut-off side of the workpiece.
- Always use a push stick when ripping small workpieces.

Transporting (fig. B)

- To transport the saw, lower the head and depress the lock down pin (17).
- Lock the table (19) into lowest position. Lock the rail lock knob with the saw head in the front position, lock the mitre arm in the far right mitre angle, slide the fence (13) completely inward and lock the bevel lever (15) with the saw head in the vertical position to make the tool as compact as possible.
- Always use the hand indentations (26) shown in fig. B to transport the saw.



WARNING: Always transport the machine in bench saw mode and ensure that the saw blade is completely covered by the upper guard. Never use any guard to carry the machine.

MAINTENANCE

Your DEWALT power tool has been designed to operate over a long period of time with a minimum of maintenance. Continuous satisfactory operation depends upon proper tool care and regular cleaning.



WARNING: To reduce the risk of injury, turn unit off and disconnect machine from power source before installing and removing accessories, before adjusting or changing set-ups or when making repairs. Be sure the trigger switch is in the OFF position. An accidental start-up can cause injury.

- If the saw blade does not stop in less than 10 seconds after switching off, have the machine serviced by an authorised DEWALT repair agent.



Cleaning

Before use, carefully check the upper blade guard, movable lower blade guard as well as the dust extraction tube to determine that it will operate properly. Ensure that chips, dust or workpiece particle cannot lead to blockage of one of the functions.

In case of workpiece fragments jammed between saw blade and guards disconnect the machine from the power supply and follow the instructions given in section **Mounting the Saw Blade**. Remove the jammed parts and reassembling the saw blade.



WARNING: Blow dirt and dust out of the main housing with dry air as often as dirt is seen collecting in and around the air vents. Wear approved eye protection and approved dust mask when performing this procedure.

 **WARNING:** Never use solvents or other harsh chemicals for cleaning the non-metallic parts of the tool. These chemicals may weaken the materials used in these parts. Use a cloth dampened only with water and mild soap. Never let any liquid get inside the tool; never immerse any part of the tool into a liquid.

 **WARNING:** To reduce the risk of injury, regularly clean the table top.

 **WARNING:** To reduce the risk of injury, regularly clean the dust collection system

Cleaning and maintaining the kerf plate (fig. U)

Regularly clean the area below the kerf plate.

If the kerf plate is worn it must be replaced.

- Remove the screws (74) holding the kerf plate (8).
- Remove the kerf plate and clean the area below.
- Re-install the parts of the kerf plate and the screws.
- Tighten the screws hand-tight.
- To adjust the kerf plate, proceed as follows:
- Pull down the head until the blade just enters the saw kerf.
- Adjust each part of the kerf plate to fit closely to the teeth of the blade.
- Tighten the screws.



Lubrication

This machine requires no additional lubrication. The bearings of the motor are pre-lubricated and watertight.

- Avoid using oil or grease as this can cause clogging with sawdust and chips and create problems.
- Clean the parts subject to accumulation of sawdust and chips periodically with a dry brush.

Optional Accessories

 **WARNING:** Since accessories, other than those offered by DEWALT, have not been tested with this product, use of such accessories with this tool could be hazardous. To reduce the risk of injury, only DEWALT, recommended accessories should be used with this product.

Support for long pieces (fig. A4)

- Always support long pieces.
- For best results, use the extension work support (28) to extend the table width of your saw (available from your dealer as an option). Support long workpieces using any convenient means such as saw-horses or similar devices to keep the ends from dropping.

Dust Collection Port (fig. A5, V)

 **WARNING!** Whenever possible, connect a dust extraction device designed in accordance with the relevant regulations regarding dust emission.

- The D27111 will accept the optional dust collection port. For installation, refer to the dust collection port instructions when purchased.
- The D27112 will accept and is supplied with the dust collection port.

Connect a dust collection device designed in accordance with the relevant regulations. The air velocity of externally connected systems shall be 20 m/s \pm 2 m/s. Velocity to be measured in the connection tube at the point of connection, with the tool connected but not running.

SAW BLADES

ALWAYS USE 305 mm SAW BLADES WITH 30 mm ARBOR HOLES. SPEED RATING MUST BE AT LEAST 4000 RPM. Never use a smaller or greater diameter blade. It will not be guarded properly. Use cross cut blades only. Do not use blades designed for fast ripping, combination blades or blades with hook angles in excess of 10°.

BLADE DESCRIPTIONS		
APPLICATION	DIAMETER	TEETH
Construction Saw Blades (thin kerf with anti-stick rim)		
General Purpose	305 mm	36
Woodworking Saw Blades (provide smooth, clean cuts)		
Fine crosscuts	305 mm	60

Consult your dealer for further information on the appropriate accessories.

Protecting the Environment



Separate collection. This product must not be disposed of with normal household waste.



Should you find one day that your DEWALT product needs replacement, or if it is of no further use to you, do not dispose of it with household waste. Make this product available for separate collection.



Separate collection of used products and packaging allows materials to be recycled and used again. Re-use of recycled materials helps prevent environmental pollution and reduces the demand for raw materials.

Local regulations may provide for separate collection of electrical products from the household, at municipal waste sites or by the retailer when you purchase a new product.

DEWALT provides a facility for the collection and recycling of DEWALT products once they have reached the end of their working life. To take advantage of this service please return your product to any authorised repair agent who will collect them on our behalf.

You can check the location of your nearest authorised repair agent by contacting your local DEWALT office at the address indicated in this manual. Alternatively, a list of authorised DEWALT repair agents and full details of our after-sales service and contacts are available on the Internet at: www.2helpU.com.

GUARANTEE

DEWALT is confident of the quality of its products and offers an outstanding guarantee for professional users of the product. This guarantee statement is in addition to and in no way prejudices your contractual rights as a professional user or your statutory rights as a private non-professional user. The guarantee is valid within the territories of the Member States of the European Union and the European Free Trade Area.

• 30 DAY NO RISK SATISFACTION GUARANTEE •

If you are not completely satisfied with the performance of your DEWALT tool, simply return it within 30 days, complete with all original components, as purchased, to the point of purchase, for a full refund or exchange. The product must have been subject to fair wear and tear and proof of purchase must be produced.

• ONE YEAR FREE SERVICE CONTRACT •

If you need maintenance or service for your DEWALT tool, in the 12 months following purchase, you are entitled to one service free of charge. It will be undertaken free of charge at an authorised DEWALT repair agent. Proof of purchase must be produced. Includes labour. Excludes accessories and spare parts unless failed under warranty.

• ONE YEAR FULL WARRANTY •

If your DEWALT product becomes defective due to faulty materials or workmanship within 12 months from the date of purchase, DEWALT guarantees to replace all defective parts free of charge or – at our discretion – replace the unit free of charge provided that:

- The product has not been misused;
- The product has been subject to fair wear and tear;
- Repairs have not been attempted by unauthorised persons;
- Proof of purchase is produced;
- The product is returned complete with all original components.

If you wish to make a claim, contact your seller or check the location of your nearest authorised DEWALT repair agent in the DEWALT catalogue or contact your DEWALT office at the address indicated in this manual. A list of authorised DEWALT repair agents and full details of our after-sales service is available on the Internet at: www.2helpU.com.

Belgique et Luxembourg België en Luxemburg	Black & Decker - DEWALT Nieuwlandlaan 7, IZ Aarschot B156 B-3200 Aarschot	Dutch Tel: 32 70 220 063 French Tel: 32 70 220 062	Fax: 32 70 225 585 Fax: 32 70 222 441 www.dewalt.be
Danmark	DEWALT Sluseholmen 2-4 2450 København SV		Tlf: 70201511 Fax: 70224910 www.dewalt.dk
Deutschland	DEWALT Richard Klinger Str. 11 65510 Idstein		Tel: 06126-21-1 Fax: 06126-21-2770 www.dewalt.de
Ελλάς	Black & Decker (Ελλάς) A.E. Στράβωνος 7 & Βουλιαγμένης 159 Γλυφάδα 16674, Αθήνα	Τηλ: 30 210 8981-616 Service: 30 210 8981-616 Φαξ: 30 210 8983-570	www.dewalt.gr
España	DEWALT Parque de Negocios "Mas Blau" Edificio Muntadas, c/Bergadá, 1, Of. A6 08820 El Prat de Llobregat (Barcelona)		Tel: 934 797 400 Fax: 934 797 419 www.dewalt.es
France	DEWALT 5, allée des hêtres BP 30084, 69579 Limonest Cedex		Tel: 04 72 20 39 20 Fax: 04 72 20 39 00 www.dewalt.fr
Schweiz Suisse Svizzera	DEWALT In der Luberzen 40 8902 Urdorf		Tel: 01 - 730 67 47 Fax: 01 - 730 70 67 www.dewalt.ch
Ireland	DEWALT Calpe House Rock Hill Black Rock, Co. Dublin		Tel: 00353-2781800 Fax: 00353-2781811 www.dewalt.ie
Italia	DEWALT c/o Energypark Building 03 sud, Via Monza 7/A, 20871 Vimercate (MB), IT		Tel: 800-014353 Fax: 39 039 9590 317 www.dewalt.it
Nederlands	Black & Decker - DEWALT Joulehof 12 4600 AB Bergen Op Zoom		Tel: 31 164 283 063 Fax: 31 164 283 200 www.dewalt.nl
Norge	DEWALT Postboks 4613, Nydalen 0405 Oslo		Tel: 45 25 13 00 Fax: 45 25 08 00 www.dewalt.no
Österreich	DEWALT Werkzeug Vertriebsges m.b.H Oberlaaerstrasse 248 A-1230 Wien		Tel: 01 - 66116 - 0 Fax: 01 - 66116 - 14 www.dewalt.at
Portugal	DEWALT Centro de Escritórios de Sintra Avenida Almirante Gago Coutinho, 132/134, Edifício 142710-418 Sintra 2710-418 Lisboa		Tel: 214 66 75 00 Fax: 214 66 75 75 www.dewalt.pt
Suomi	DEWALT Tekniikantie 12 02150 Espoo, Finland		Puh: 010 400 430 Faksi: 0800 411 340 www.dewalt.fi
Sverige	DEWALT Box 94 431 22 Mölndal		Tel: 031 68 61 00 Fax: 031 68 60 08 www.dewalt.se
Türkiye	KALE Hırdavat ve Makina A.Ş. Defterdar Mah. Savaklar Cad. No:15 Edirnekapı / Eyüp / İSTANBUL 34050 TÜRKİYE		Tel: 0212 533 52 55 Faks: 0212 533 10 05 www.dewalt.com.tr
United Kingdom	DEWALT 210 Bath Road; Slough, Berks SL1 3YD	Tel: 01753-56 70 55 Fax: 01753-57 21 12	www.dewalt.co.uk
Middle East Africa	DEWALT P.O. Box - 17164, Jebel Ali (South Zone), Dubai, UAE		Tel: 971 4 8863030 Fax: 971 4 8863333 www.dewalt.ae